

ELECTRICAL INSTALLATION MANUAL

UltraClear WASTE WATER TREATMENT SYSTEMS

MODELS - ST10, ST8 & Commercial Systems

ELECTRICAL CIRCUIT SPECIFICATIONS ULTRA CLEAR AWTS

(For use with plastic turret; float switch for high water)

IMPORTANT: This manual must be given to your electrician with the control box and the alarm panel. Must be installed by a licensed electrician.

The Ultra Clear AWTS warranty will be void if these Specifications are not adhered to.

The power source circuit is to be connected to a dedicated single phase plus earth circuit, protected by a 15 amp MINIMUM circuit breaker of 8Ka and marked as **ULTRA CLEAR**. Minimum cable size 2.5mm TPS to connect to the supply.

The alarm panel is a low voltage device (12 volt data) that decodes a data signal from the main control box at the treatment tank. The alarm cable may be run in the same conduit, although this is a low voltage circuit. It is normal practice to use 1mm squared twin TPS if the alarm plate conductor is in the same conduit as the power feed.

All conduit joints must be glued, and 25mm flexible conduit used to enter the equipment housing. The conduit must be looped with a weep hole at the lowest point to allow any water that may accumulate within the conduit to drain before entering the electronic controller enclosure. Water ingress will void warranty.

The alarm panel is powered by 12 volt data. When testing alarm allow 1 minute for audible response.

The alarm panel has three LEDs. **Under normal operating conditions, the green power led will light.** To test alarm disconnect air blower, and led will flash blue on control box and red on alarm plate.

The air blower and irrigation pump outlets are interchangeable. The micro computer can analyse the current being consumed from any outlet, and distinguish where the blower is to monitor its alarm. The low voltage alarm circuit is not polarity sensitive and may be connected any way around.

There is a 15 amp fast blow fuse to protect the pumps. Should the fuse holder lamp be lit, the fuse is open circuit. A spare fuse is supplied under the controller enclosure cover, together with photos of correctly terminated cabling to the control unit and alarm plate.

NOTE: Electrical work must be carried out in accordance with A.S. 3000 and appropriate Supply Authority Rules. A "Notification of electrical work" certificate must be lodged with the Supply Authority for your wiring.

WARNING

Water resistant control box IP55.

**Power supply to be made on external points of control box only.
The intrusion of control box will void warranty.**

HIGHLAND TANKS PTY LTD

ACN 090 907 725 ABN 93 090 907 725

PO BOX 1158, MITTAGONG NSW 2575

Phone: 0419 545 319 Fax 02 4872 4109

Email: sales@highlandtanks.com.au www.ultraclear.com.au

UCAWTSEIM 137
Revision 1 11/10/2019
Page 1

ELECTRICAL INSTALLATION MANUAL

UltraClear

WASTE WATER TREATMENT SYSTEMS

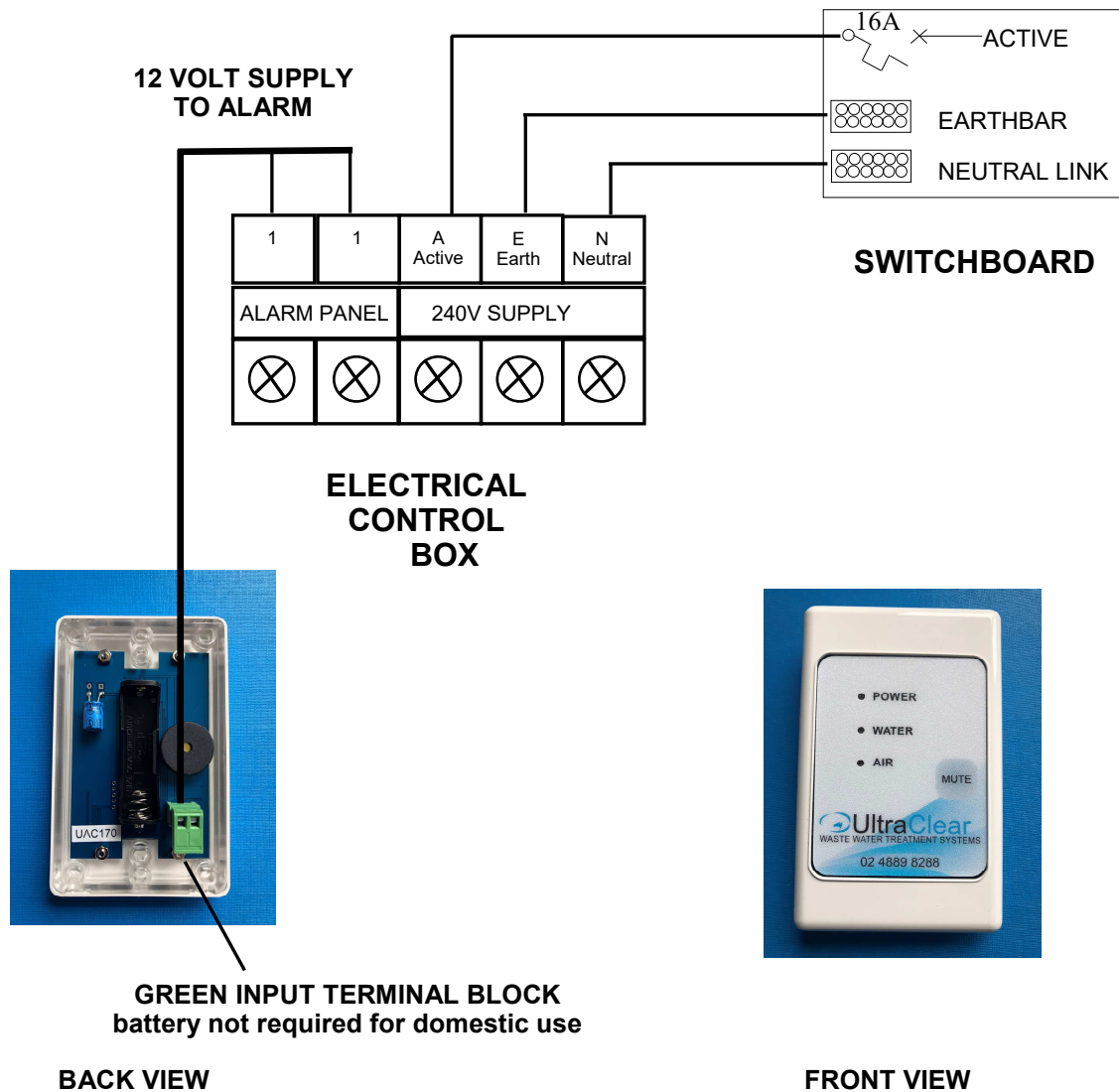

ALARM PANEL FITTED IN HOUSE

Ultra Clear WASTEWATER TREATMENT SYSTEMS

ELECTRICAL CONTROL SYSTEM

DRAWING NOT TO SCALE