

HIGHLAND TANKS PTY LTD trading as
ULTRA CLEAR

WASTEWATER TREATMENT SYSTEMS

ACN 090 807 725
PO BOX 1158, MITTAGONG NSW 2575
PHONE: 02 4889 8288 FAX: 02 4889 8566

AERATED WASTEWATER TREATMENT SYSTEM

MODEL ST10
SUITABLE TO DEAL WITH WC'S & ALL WASTE
ON RESIDENTIAL PREMISES.

Drawn by: L. TASKER Design by: D. W. REBBECK

SPECIFICATION FOR

Name _____
Installation _____
Address _____
No. of Persons _____

Chamber Total		Capacity
No.	Capacity	Description
1	2001 Ltrs	Primary Chamber 1
2	1005 Ltrs	Primary Chamber 2
3	1273 Ltrs	Aerobic Chamber 1
4	1273 Ltrs	Aerobic Chamber 2
5	433 Ltrs	Settling Chamber
6	591 Ltrs	Disinfection Pump Chamber

Tested at 2137 litres per day

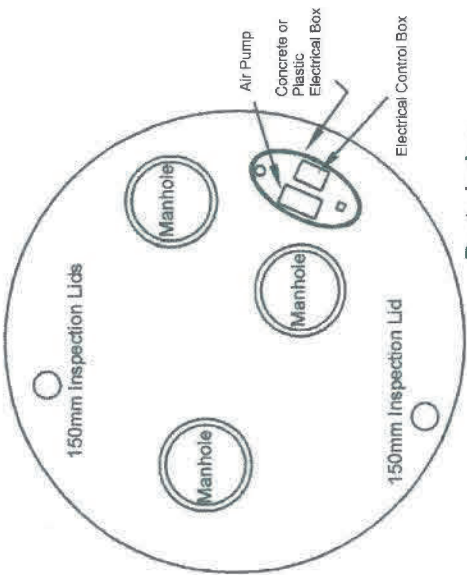
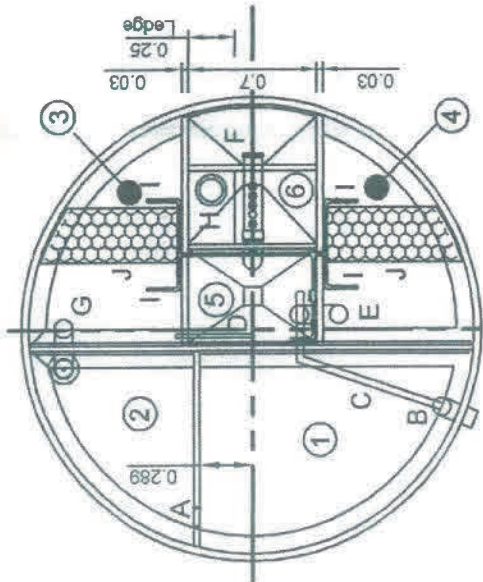
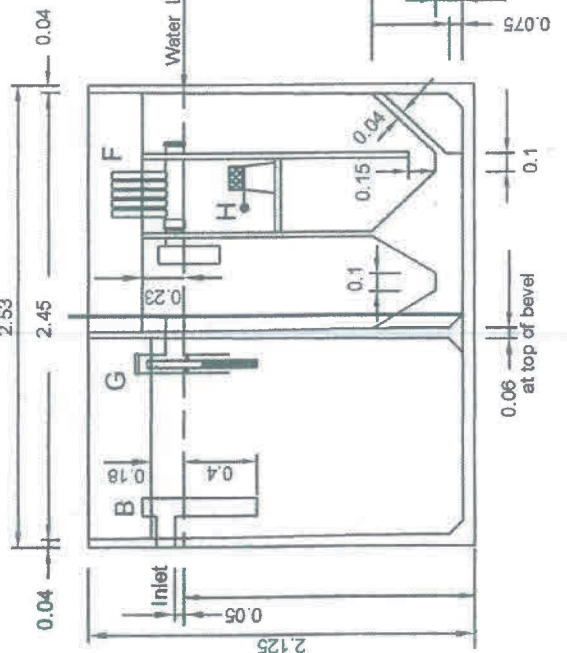

Parts Index

No.	Description
A	Flow Hole Primary 1 to Primary 2
B	Inlet Square
C	Sludge Return Pipe
D	Scum Skimmer
E	Flow Pipe Aeration to Settling Chamber
F	Chlorinator
G	Flow Restrictor
H	Pump Ledge and Pump
I	Air Diffuser Line
J	Media Pack

NSW MINISTRY OF HEALTH

APPROVED

19 SEP 2016

COLLECTION WELLS manufactured by Highland Concrete Tanks
PO BOX 1158, MITTAGONG NSW 2575 Factory: 16 Gantry Place, BRAEMAR

Phone: 02 4889 8288 Fax: 02 4889 8566

All Septic Tanks & Collection Wells are manufactured to comply with
Australian Standards AS/NZS 1546.1:2008

All internal and sundries supplied by
ULTRA CLEAR WASTEWATER TREATMENT SYSTEMS

UCST10SD 25 Revision 6 29/09/2016