

PLUMBER'S INSTALLATION MANUAL

Ultra Clear WASTE WATER TREATMENT SYSTEMS MODEL ST10 10 person single tank system

HIGHLAND TANKS PTY LTD
ACN 090 907 725 ABN 93 090 907 725
PO BOX 1158, MITTAGONG NSW 2575
Phone 02 4889 8288 or 02 4889 8562
Fax 02 4889 8566
Email: ultracl@hinet.net.au
www.ultraclear.com.au

1. Excavation of hole to drawing specifications, allowing 50-100mm above ground level as shown.
2. Lid depth 75mm. Install tank in hole with level bottom, using 50mm depth sand or metal dust aggregate base.
3. Connect drainage to tank.
4. Ensure E duct vents are constructed.
5. Half fill tank with water to prevent lifting of tank.
6. Backfill tank.
7. It is the plumber's or owner's responsibility to provide all weather access for delivery truck to the excavated hole. **Ensure access is free of power lines and overhanging trees.**
8. Location of tank – avoid storm water run off areas.
9. When backfilling tank ensure no large rocks enter hole. Any damage to tanks, e.g. large rocks or machinery damage, during backfilling, is the responsibility of the contractor and/or owner.
10. **Tank must be installed on level base using 50mm depth sand or aggregate**, with no rocks protruding over surface area. Any damage to tanks due to incorrect installation is the responsibility of the contractor and/or owner and is not covered by warranty.

MODEL ST10 HOLE EXCAVATION

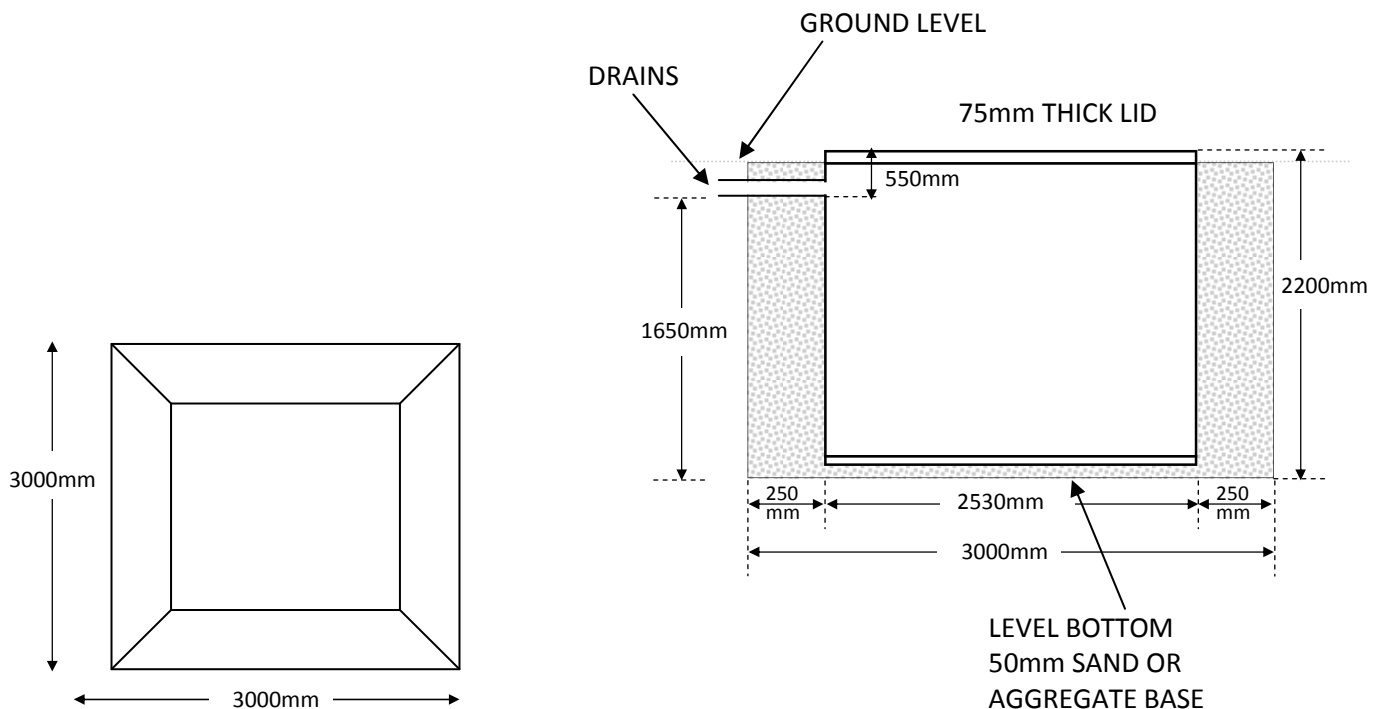

- Bottom of hole level
- Hole depth approx. 2150mm
- Lifting eyes at base of tank
- Allow 300mm access around tanks to release hooks
- NOT TO SCALE