

ELECTRICAL INSTALLATION MANUAL

NUMBER 2 - April 2010

UltraClear

WASTE WATER TREATMENT SYSTEMS

MODELS - ST10, ST8 & Commercial Systems

ELECTRICAL CIRCUIT SPECIFICATIONS ULTRA CLEAR AWTS

IMPORTANT: This manual must be given to your electrical contractor with the control box and the alarm panel.

The Ultra Clear AWTS warranty will be void if these Specifications are not adhered to.

The power source circuit is to be connected to a dedicated single phase plus earth circuit, protected by a 16 amp MINIMUM circuit breaker of 8Ka or greater type suitable for motor start, such as Weber/Martec As168 type or Clipsal "U" type; and marked as **ULTRA CLEAR**. Minimum cable size 2.5mm. Connected to and run from an EXTERNAL building switchboard.

The alarm panel is a low voltage device (12 volt) that decodes a data signal from the main control box at the treatment tank. A two conductor cable with a minimum cross sectional area of 0.8mm per conductor is required to inter-connect the two. It is normal practice to use 1mm squared twin TPS if the alarm plate conductor is in the same conduit as the power feed. The two conductors are not polarity conscious, and may be connected any way around.

The alarm panel is fitted with a rechargeable backup battery which has been left disconnected from factory and must be connected before final installation in the wall. Use a small screwdriver to lever the connector onto the battery.

The alarm panel has three leds. **Under normal operating conditions, the green power led will light.** If power supply to the treatment system fails, the power led will flash on briefly every 3 seconds, and the alarm will give a brief beep in sequence with the power led. This beep can be muted for 24 hours.

NOTE: Electrical work must be carried out in accordance with A.S. 3000 and Supply Authority Rules. A "Notification of electrical work" certificate must be lodged with the Supply Authority for your wiring.

Continuous running current is 0.6 amp with a maximum intermittent current up to 3.1 amps (dependent upon submersible pump size).

WARNING: Water resistant control box IP55. Power supply to be made on external points of control box only. The intrusion of control box will void warranty.

HIGHLAND TANKS PTY LTD

ACN 090 907 725 ABN 93 090 907 725

PO BOX 1158, MITTAGONG NSW 2575

Phone 02 4889 8288 or 02 4889 8562 Fax 02 4889 8566

Email: ultracl@hinet.net.au www.ultraclear.com.au

UCEIM 75
Revision 1
27 April 2010

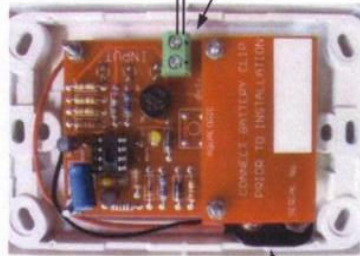

ALARM PANEL
FITTED IN HOUSE

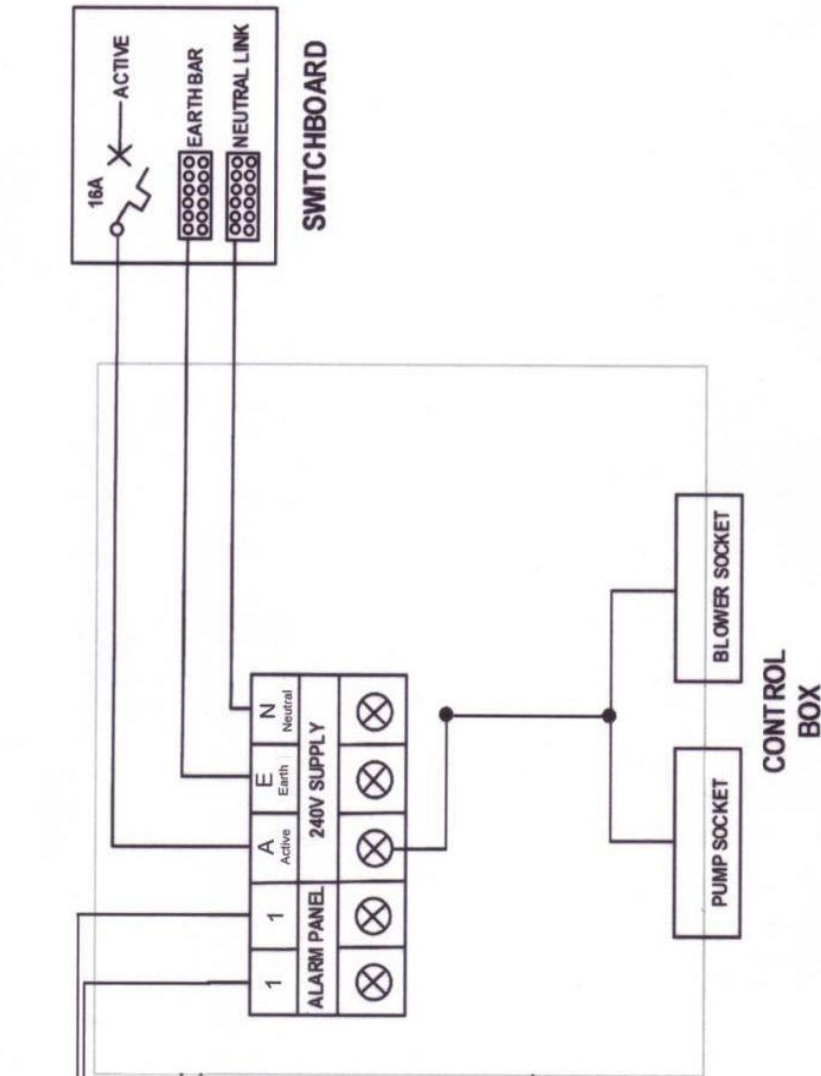

DRAWING NOT TO SCALE		Ultra Clear Wastewater Treatment Systems	
DRAWN	ER	TITLE	ELECTRICAL CONTROL SYSTEM
Revision 1 27/04/2010		DATE	01/01/2010
		SIZE	A4
		DWG. NO.	UC EIM 75
		SCALE	NTS
		SHEET 1 OF 1	